



INNOVATIVE
PEARLBOND™
AND PEARLSTICK™
TPU SOLUTIONS
FOR ADHESIVES

Lubrizol

Engineered Polymers

LUBRIZOL ENGINEERED POLYMERS OFFERS A BROAD RANGE OF TPUS TO THE ADHESIVE INDUSTRY

TABLE OF CONTENTS:

Key Benefits.....	1
Introduction.....	2
A World of Applications.....	3
Pearlbond™ TPU for Solvent-Free Adhesives.....	4
- Holt Melt Adhesives.....	5
- Reactive Hot Melts.....	6
Pearlstick™ TPU for Solvent-Based Adhesives...	9
Inks, Binders, Lacquers and Other Uses.....	13

When considering thermoplastic polyurethanes (TPUs) for use in adhesives, the Lubrizol Engineered Polymers product offering can be found in the following segments:

- Solvent-based adhesives
- Hot melt adhesives (powder and film)
- Reactive hot melts (HMPUR or RHM)
- Inks, binders and lacquers

KEY BENEFITS

The Pearlbond™ and Pearlstick™ TPU low and high melting point product offering uniquely positions Lubrizol to satisfy customers' melting range needs across a wide crystallization range. This combined adhesive product offering can be applied over a broad range of applications, such as apparel, footwear, furniture, construction, medical garments, and wood structures.

Lubrizol offers an broad TPU offering to the adhesives industry. Available in pellet and/or powder form, our products meet customer requirements for high-performing properties and benefits including:

- Low to high melting point (50-150 °C)
- Slow to very fast crystallization rate
- Broad processing window: heat activation across a wide range of temperatures
- Good adhesion to polar substrates (e.g. polyester textiles) and materials such as PVC, ABS...
- TPUs that can be converted into hot melt film via flat die and/or blown film extrusion
- TPUs for inks, binders, lacquers and other end-uses
- TPUs that can be added to polyurethane pre-polymers as a property modifier (HMPUR)
- TPUs that can be dissolved into solution (solvent-based adhesives)



A PORTFOLIO OF INNOVATIVE POLYMER SOLUTIONS

Customers choose Lubrizol Engineered Polymers' innovative solutions for the outstanding physical and aesthetic properties they provide in many industrial, sports, recreational and consumer goods applications.

Our polymers bridge the gap between flexible rubber and rigid plastics, with a wide variety of physical and functional property combinations. We help customers solve some of the industry's toughest challenges, making products safer and stronger for better end-use performance, often while simultaneously improving aesthetic and sustainable measures.

Advancing materials and elevating performance - both our mission and our passion.

PRODUCTS

- **Pearlbond™ TPU** for use in hot melt adhesives and HMPUR
- **Pearlbond™ ECO: Bio TPU™** for hot melt adhesives and HMPUR, made with 59% and 67% renewable-sourced content respectively determined according to ASTM D6866.
- **Pearlstick™ TPU** for use in solvent-based adhesives, and inks, binders, lacquers and other uses.





A WORLD OF APPLICATIONS

PEARLBOND™ TPU FOR SOLVENT-FREE ADHESIVES

PEARLBOND™ TPU FOR HOT MELT ADHESIVES (HMAs)

Pearlbond™ TPU for HMAs is toluene-free and is used for thermobonding (heat sealable) processes through which the adhesive is laid on a series of substrates, and then treated with heat and pressure for bonding. It can be applied on fabrics, shoe stiffeners (toe puffs and counters) and adhesive films.

Lubrizol TPU grades for hot melts are available with the following properties:

- Low to high melting point (50->140 °C)
- Slow to very fast crystallization rate
- Oeko-Tex® compliant grades available upon request

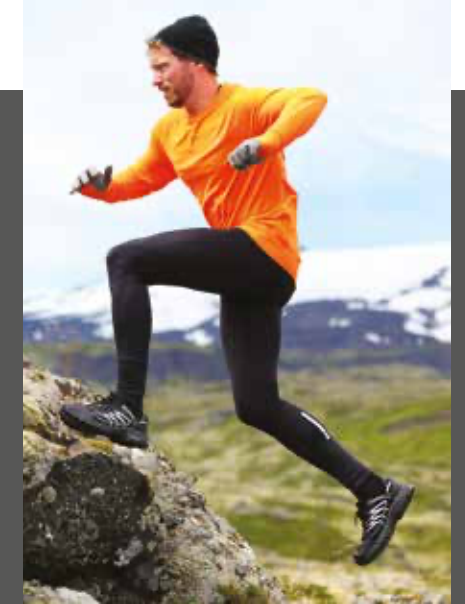

Lubrizol offers a comprehensive TPU product range to the adhesives industry. Below is an overview of some of the possibilities offered by our Pearlbond™ and Pearlstick™ grades.

Industry	Solvent-Based Adhesives	Reactive Hot Melt	Hot Melt Powder TPU	Hot Melt Adhesive Film & Sheet	Dispensed Hot Melt
Automotive interior trim	X	X	X	X	X
Automotive filter assembly		X			
Automotive foam-fabric bonding	X		X	X	
Automotive plastic-to-metal bonding		X			
Footwear sole bonding	X				
Footwear shoe stiffeners			X	X	
Furniture wood-PVC lamination	X				
Furniture woodworking		X			
Furniture edge banding		X			X
Tie coats for coated fabrics	X				
Book binding		X			X
DIY adhesives	X			X	
Seam tapes for apparel			X	X	
Motives & label adhesives	X		X		

Table 1: Lubrizol TPU technologies in end applications.

Lubrizol has significantly expanded the range of formulation solutions available when considering solvent-free HMAs. There are three new product series:

- A.** Pearlbond™ 300 plasticizer-free series is soft-touch, absent of residual surface tackiness, has excellent processability and good grip/anti-slip properties. Thanks to the unprecedented low viscosity of this series it can be processed on a slot-die equipment. Latest developments include color-stable grades with very good UV and washing resistance.

Typical industries or applications that benefit from the Pearlbond™ 300 TPU series include: textile lamination, automotive, footwear, electronics, outdoor equipment, furniture, synthetic leather, elastic seam tapes and heat transfer labels.
- B.** Pearlbond™ 900 TPUs are soft, plasticizer-free polymers that combine outstanding weatherability (resistance to UV, hydrolysis, and harsh solvents) and very strong bonding strength to a multitude of substrates such as PET, PA fabrics, cotton and many other textiles.
- C.** Our bio-based TPU solutions for adhesives have been expanded with the addition of Pearlbond™ ECO 590 HMS TPU for hot melt adhesives. This high-performing resin with 59% content from a renewable source according to ASTM D6866 can be applied by adhesive formulators or designers in furniture, edge banding, electronics, hot melt film, textile lamination, seam tape, footwear, and transportation. It shows excellent processability in flat cast extrusion and blown extrusion.

ADHESIVE FILM AND WEB

PEARLBOND™ TPU FOR REACTIVE HOT MELTS



Lubrizol has a broad offering of TPUs that can be processed via extrusion processes to make adhesive film and/or web. Lubrizol TPUs are available in different hardnesses, across a wide range of melting points (50->140 °C), and crystallization rates (slow, medium, fast and extremely fast).

Powder: Lubrizol TPU grades are typically supplied in the form of pellets. These can also be made available in powder form. Depending on the TPU grades and order sizes, various average particle sizes can be made available such as: <100 µm, <250 µm, <355 µm, < 500 µm and < 800 µm.



THERMOBONDING

Lubrizol has developed a range of TPUs that are specifically adapted to thermobonding and more specifically to processes such as: scatter, paste dot, powder dot, double dot, screen coating, and engraved roller coating to name the most commonly used processes.

THERMOBONDING POWDER COATING SYSTEMS

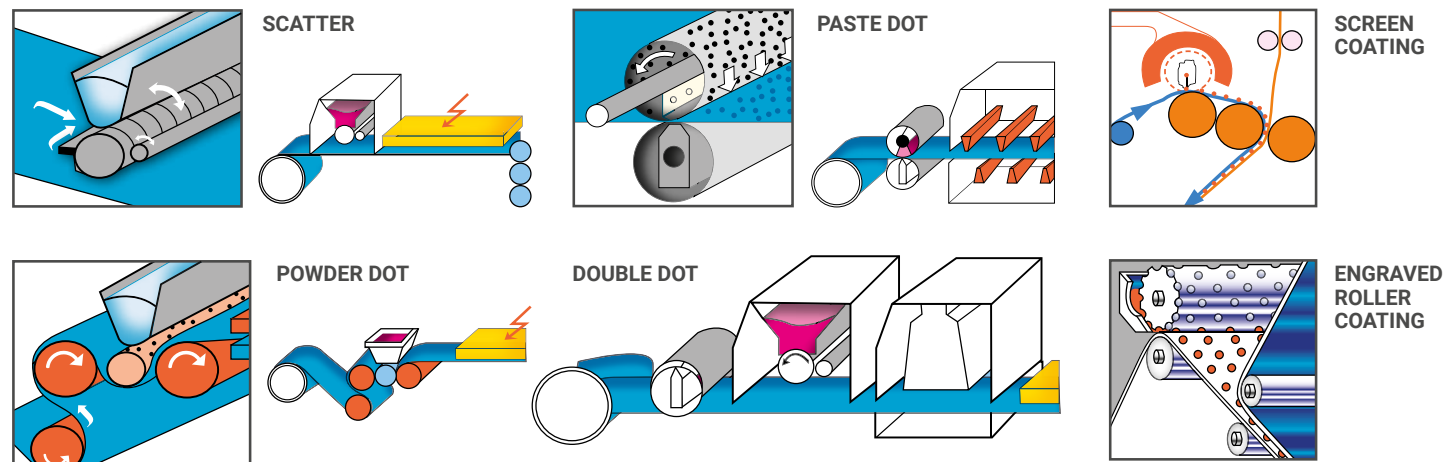

PEARLBOND™ TPU FOR REACTIVE HOT MELTS (HMPUR / RHM)

A special TPU such as Pearlbond 520 can be added to the pre-polymer to:

Increase the green strength*

Control the setting time & open time

Adjust melt viscosity

*The mechanical strength which a compacted powder must have in order to withstand mechanical operations to which it is subjected after pressing and before sintering, without damaging its fine details and sharp edges.

Polyurethane HMPUR are solid prepolymers with a low melting point. These prepolymers (**Figure 1.**) are obtained by reaction of a polyol (polyester, polyether) with a di-isocyanate in excess.

Figure 1. Formation of a HMPUR (RHM)

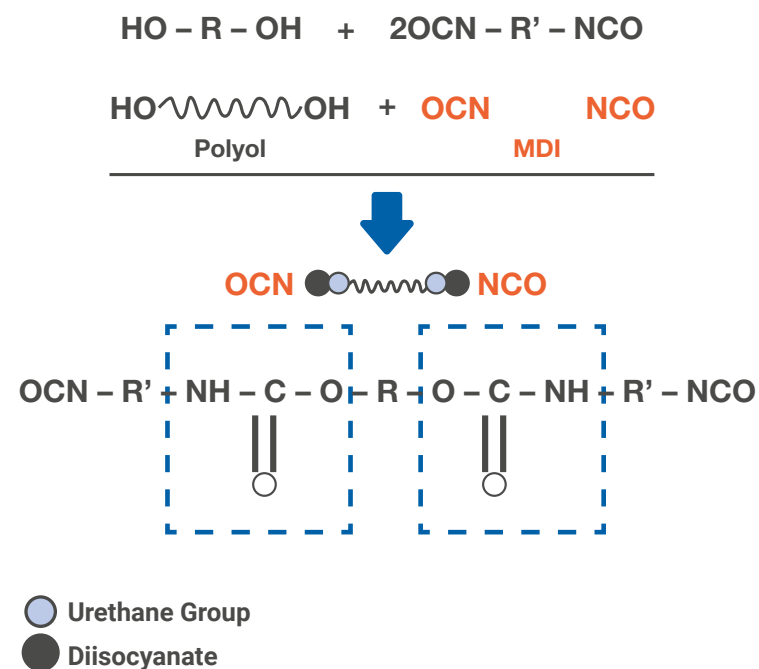

The resulting prepolymers are transferred in melt state from the production reactor to the packaging, which are sealed (preferably with a nitrogen blanket) so as to avoid exposure to ambient moisture while the RHM is solidifying and cooling. These solid prepolymers have a melting point lower than the conventional hot melts (EVA, polyolefins, polyesters, polyamides).

Depending on the requirements, the melting viscosity can vary between 4,000 and 60,000 mPa.s at 130 °C. The resulting HMPUR will have high green strength and a molecular weight high enough to allow high cohesive strength and adhesion to a variety of substrates.



HMPUR (RHM) IS A TWO-STEP REACTIVE SYSTEM

When applied at a relatively low temperature (90-140 °C), polyurethane prepolymers (RHM) flow well and can adequately wet the surface of the adhering material.

In the first phase, also called physical crosslinking (**Figure 2.**), green strength develops as a result of the cooling process (as also happens with a conventional hot melt), together with the crystallization of the soft segments that can be found in the polyol's component.

Figure 2. Physical crosslinking

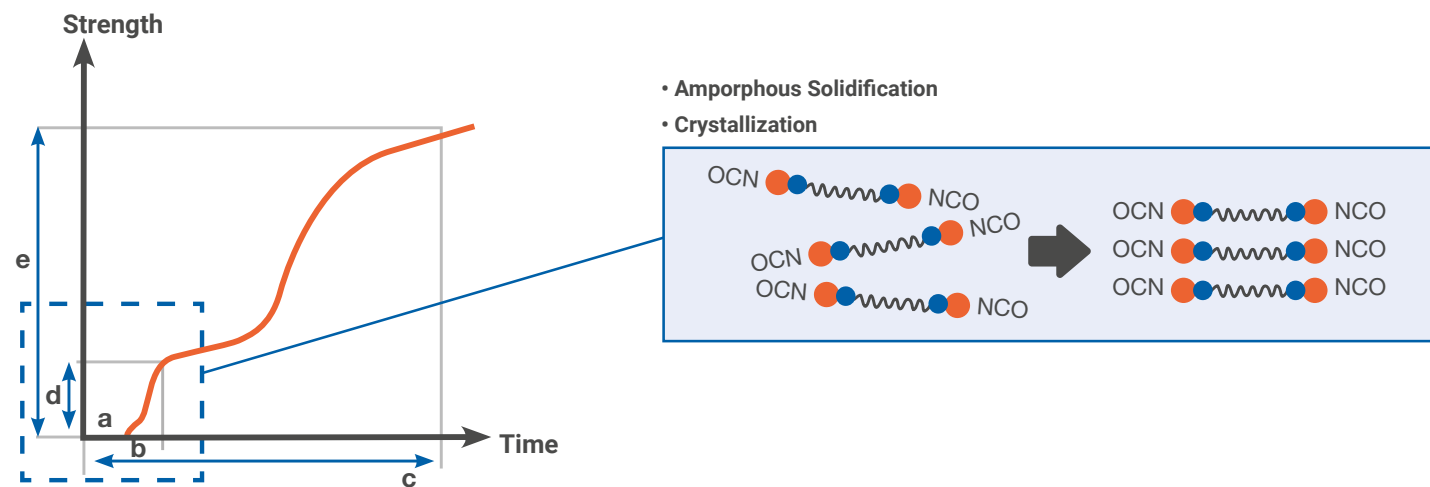

a: Open time **b:** Setting time **c:** Curing time **d:** Green strength **e:** Ultimate strength

In a second phase, or chemical crosslinking (**Figure 3.**), the isocyanate groups start to react with the ambient moisture and/or the moisture of the materials.

As a result, an increase in the molecular weight is produced and a fully reacted polymer is obtained after some time, where urethane and urea groups alternate. This allows stronger and lasting adhesive bonding, which cannot be melted again as happens with conventional hot melts.

Figure 3. Isocyanate groups react

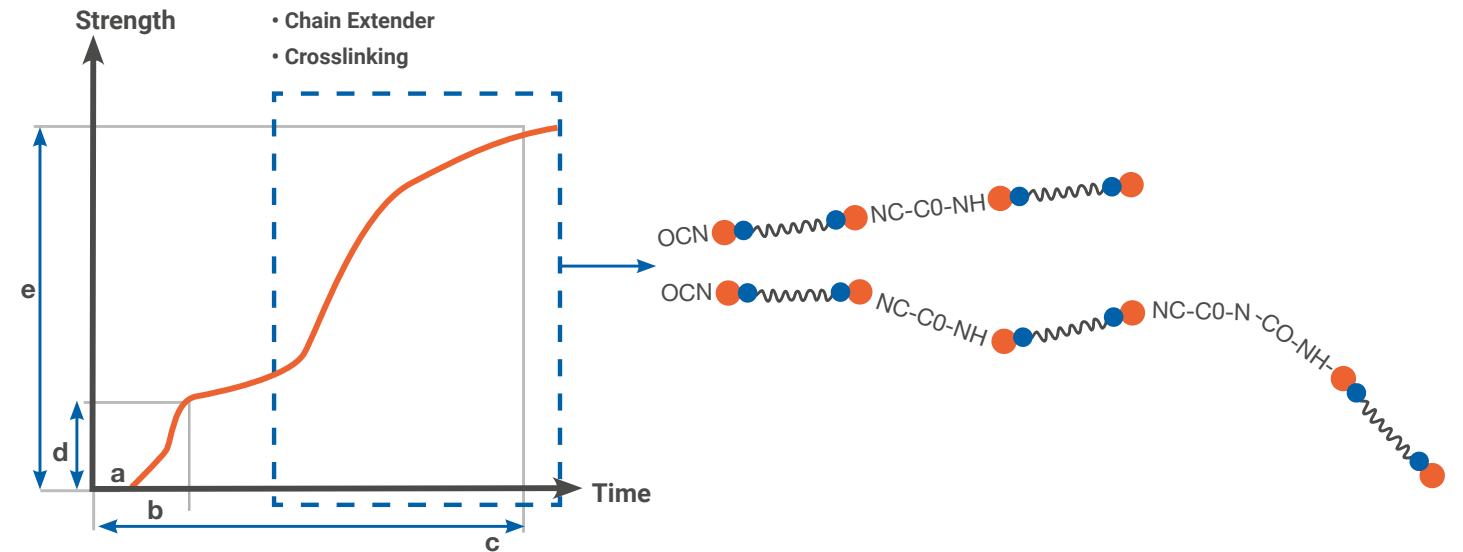

a: Open time **b:** Setting time **c:** Curing time **d:** Green strength **e:** Ultimate strength

Generally speaking, the benefits offered by the HMPUR as a result of their structure, versus the conventional hot melts can be summarized as follows:

- Lower application temperature
- Immediate green strength and rapid increase of the cohesive strength (crosslinking)
- The cross-linked adhesive has an excellent resistance to heat and ambient conditions.
- Better adhesion to a variety of substrates

TYPICAL HMPUR (RHM) FORMULATION

OH / NCO RATIO = 1: 1.95	
Crystalline Polyester (High Crystallinity)	30
Polyester (Amorphous Solid)	32
Polyester (Amorphous Liquid)	14.80
Pearlbond™ TPU	10.00
MDI	13.20
	100.00

PRODUCTION PROCESS:

- Melt the polyester polyol at 100 °C
- Charge molten polyester polyol and add Pearlbond™ TPU
- Start agitation and elimination of moisture by N2 at < 10 mbar and 120 °C, (time ≈1-2 hours)
- Reaction with excess diisocyanate at 120 °C under N2 atmosphere (time ≈1 hour)
- Filter the melt (depending on application)
- Fill into sealed containers
- Quality control (% NCO, etc.) at 24 hours

Basic purpose of the Pearlbond™ TPU grades is to modify some of the properties inherent to reactive hot melts are based on urethane pre-polymers. These crystalline TPU grades are typically used in the following industries: automotive (e.g. automotive interior parts), bookbinding, furniture (profile wrapping or edge bonding), textile, and footwear; as well as in various fixing adhesive applications.

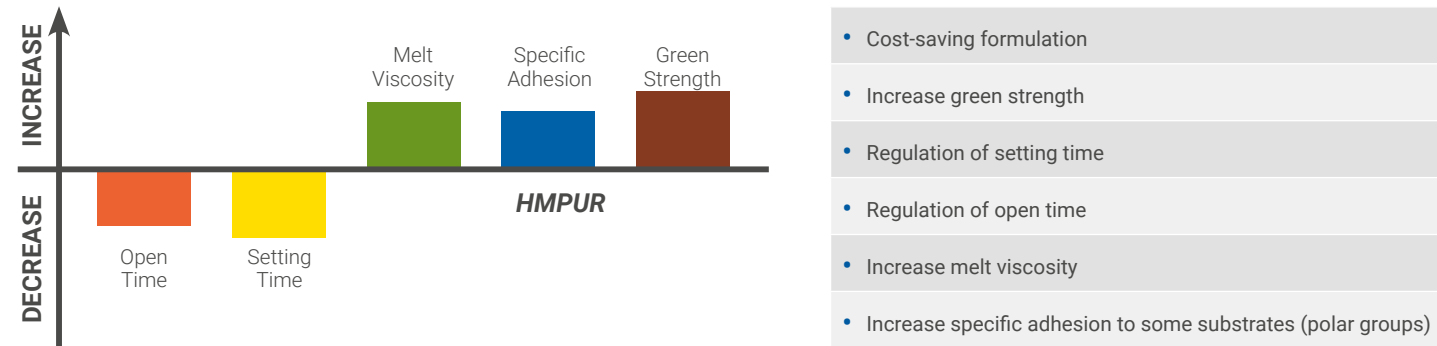

HOT TACK

By means of the Tack Tester, we can reproduce this property very well (for instance, the bonding of a shoe sole to the upper) by adjusting and studying production variables, such as: activation temperature, time allowed before bonding, materials, bonding temperature and pressure.

¹In sole bonding, the adhesive should have high hot tack so as to guarantee a perfect initial bonding, even at relatively low temperatures. Studies performed with some Pearlstick™ TPU grades are shown in the graph.

Hot-Tack¹ (PVC/Split leather) (Pressure: 2 kg/cm², Contact time: 4 sec)

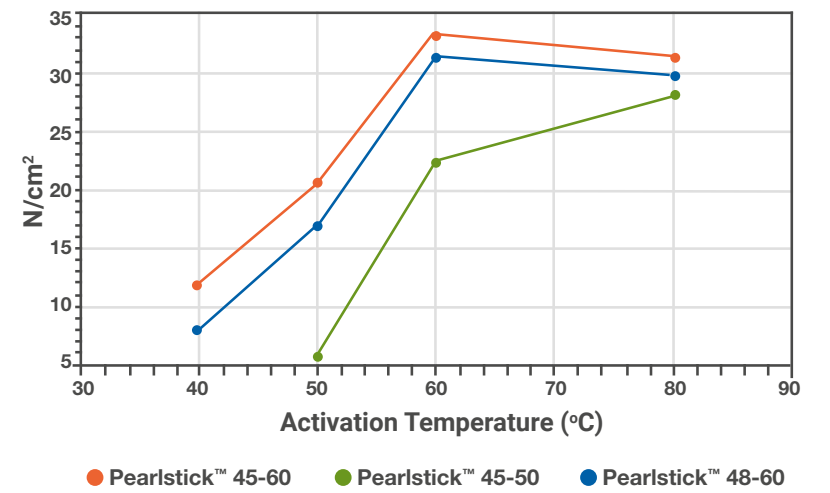

PEARLSTICK™ TPU FOR SOLVENT-BASED ADHESIVES

Pearlstick™ TPU grades have a key distinct feature, they are mainly crystalline polymers with strong properties at ambient temperature and a low melting point of the crystalline areas (50-60°C). The different Pearlstick TPU product series vary from each other mainly in their structures (different relation between hard and soft segments), their polyol types, and their different molecular weights. Some of their main general properties are described below and used to compare the different Pearlstick TPU series.



CRYSTALLIZATION RATE AND THERMOPLASTICITY

Crystallization rate is a measure of the time needed for a film of TPU adhesive to reach its maximum value in the cooling period following its heat activation (measured by Lubrizol's Standard MQSA no.12A). Thermoplasticity is the property describing the softening or melting under temperature effects. It is measured in terms of modulus of deformation (MPa) relative to temperature - in accordance to Lubrizol's Standard MQSA N° 68A, and is obtained by a "Modulus of dynamic mechanical tests". The graph to the right shows crystallization rate and thermoplasticity of different Pearlstick® TPU families.

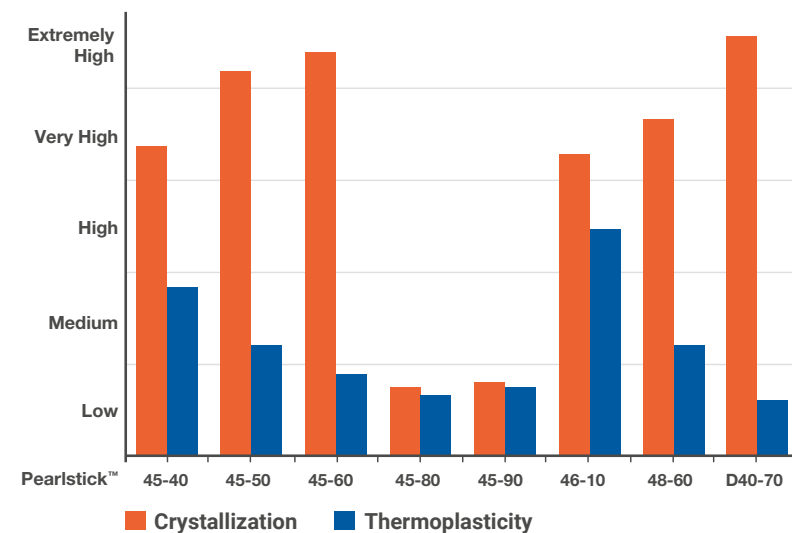

PEEL STRENGTH VERSUS ACTIVATION TEMPERATURE

Achieving optimal adhesive strength at a given temperature is vital for an adhesive film. The graph to the right shows Peel strength and Activation temperature of different Pearlstick TPU series:

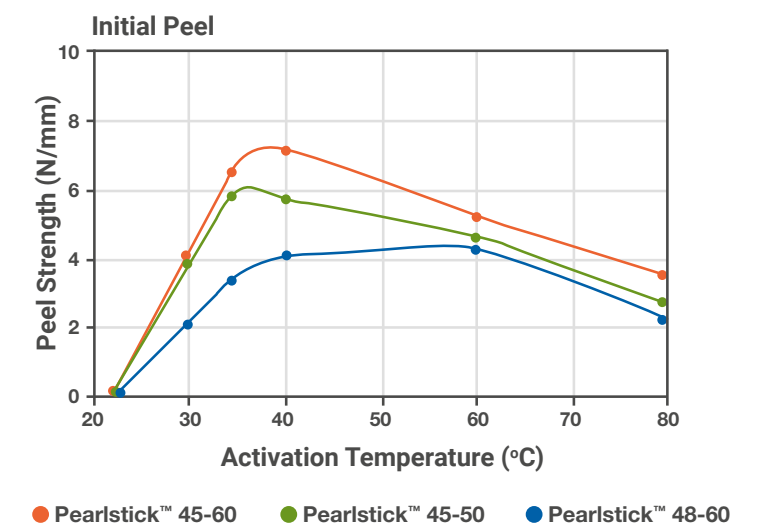

EASY SOLUBILITY

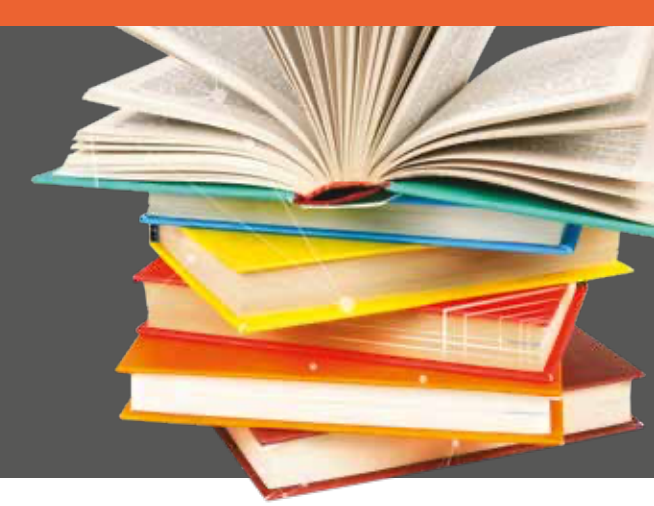

The mechanism by which a linear TPU changes from solid to liquid form in the presence of a solvent when a solution is prepared, can be described as follows:

Firstly, the TPU swells and then, progressively, due to the absorption of the solvent by the solid, it takes the aspect of a viscous solution, and a homogeneous solution is eventually formed. The swelling corresponds to the penetration of the solvent in the TPU molecules, followed by the absorption and combination of the TPU with the solvent. Such a combination results in a progressive separation of the macromolecules, breaking the intermolecular bonds (hydrogen bridges) and destroying the forces that form the initial structure. Such forces are much weaker in the crystalline phase (soft segment) than in the amorphous phase (hard segment). When all the links are broken, the macromolecules can move easily, and a homogeneous solution is then obtained.

Depending on the solvent mixture and on the given amount of intermolecular forces, the capacity of separating and breaking the links that join the macromolecules will be different. If such links are not broken (due either to a faulty stirring, or little solubility of the solvent mixture), the final solution will tend to return to its initial structure, and eventually form a non-homogeneous solution (gelled solution).

The solubility of the different Pearlstick® TPU families in several solvents and some of their mixtures has been obtained following a stirring process with a shear effect (COWLES), with a solid content of 15% and an agitation speed of 1330 rpm for 3 hours (Lubrizol's Standard MQSA N° 55A). The solubility has been checked after stirring and by visual control.

Specific Lubrizol engineered polymer grades can be dissolved in a solvent solution. Depending on the desired performance, adhesive formulations can be achieved with a dry content of 14-19%. In particular cases, the dry content can be raised up to 40% (spray adhesives).

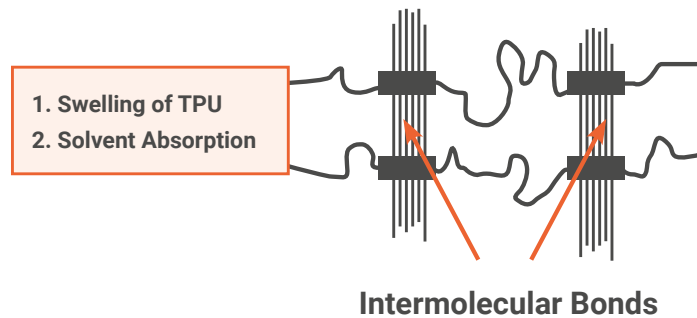
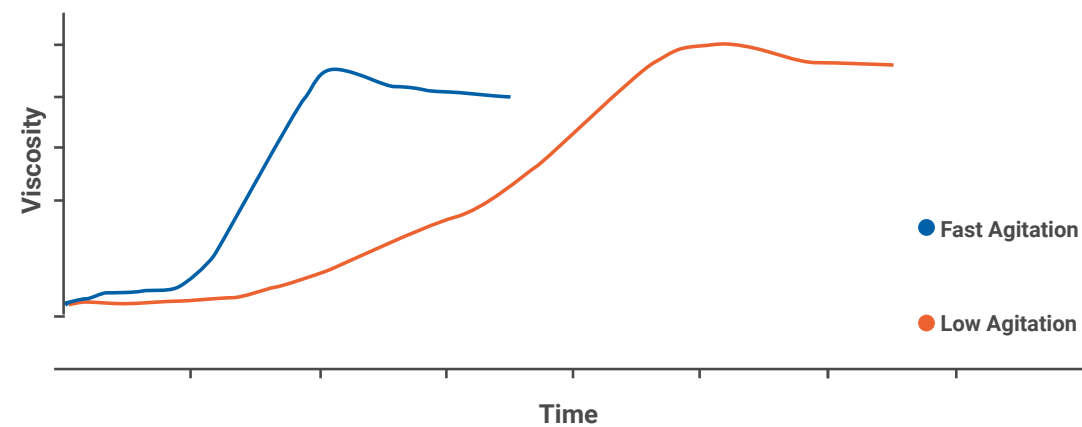

Depending on the needs of the customers and end-users, Lubrizol grades can offer the following key features:

- Good wash and/or dry-cleaning resistance
- Food compliance
- Adhesion to tight fabrics
- Low to high hardness
- Chemical, fungi and hydrolysis resistance
- Low to high heat activation
- Short to long hot tack time
- Transparency, glossiness
- Sprayability

Depending on the grades, the following solvents can be used:

- Acetone
- MEK
- THF
- Cyclohexanone
- Ethyl Acetate
- Isobutyl Acetate
- Methylene Chloride
- Trichloroethylene
- 1.1.1. Trichloroethane
- Toluene
- Xylene
- Acetone/Toluene (70:30)
- MEK/Toluene (80:20)
- MEK/Ethyl Acetate (80:20)

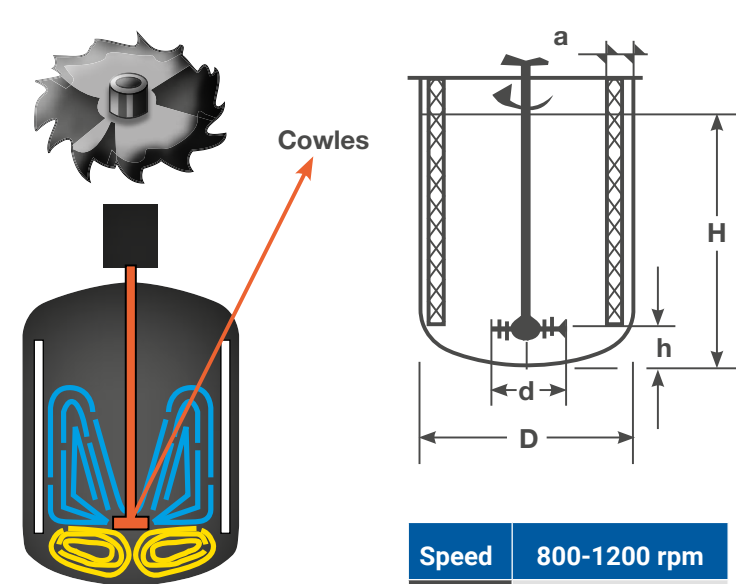

Speed	800-1200 rpm
H	(1.15) d
h	(0.5-1) d
d/D	0.5
a	(0.1-1.3) d

A typical TPU to be dissolved at a dry content of 18% is Pearlstick™ 45-60/18.

Lubrizol recommends the following equipment and dissolution conditions as explained on the left.



INKS, BINDERS, LACQUERS AND OTHER USES

Lubrizol also provides Pearlstick and Pearlbond grades to be applied in inks, binders and lacquers. These applications typically require the TPUs to be dissolved in a solvent and then combine with other additives and components. Other end-uses include synthetic leather and primers.





LUBRIZOL GLOBAL PRESENCE

Our global presence means we have the application and development laboratories (with technical service ability) already in place, as well as worldwide production capabilities and renowned customer service. We are also a specialty producer of performance coatings and other unique products for apparel. Teaming with Lubrizol simplifies a complex global supply chain.

AMERICAS

Lubrizol Advanced Materials, Inc.
9911 Brecksville Road
Cleveland, Ohio 44141-3201
USA Phone: +1 216 447 5000

ASIA

Lubrizol Specialty Chemicals
Manufacturing (Shanghai) Co., Ltd.
6F - No.3, Building C,
Lane 227, Dongyu Road
Pudong New District, Shanghai,
PRC 200126
Phone: +86 21 3866 0366

EUROPE, MIDDLE EAST, INDIA & AFRICA

Lubrizol Advanced Materials
Spain S.L. Gran Vial, no. 17
08160 Montmeló (Barcelona)
Spain
Phone: +34 93 579 9522



Lubrizol

Engineered Polymers

THE SELLER MAKES NO WARRANTIES, EXPRESS OR IMPLIED, INCLUDING, BUT NOT LIMITED TO, THE IMPLIED WARRANTIES OF MERCHANTABILITY AND FITNESS FOR A PARTICULAR PURPOSE. Nothing contained herein is to be considered as permission, recommendation, nor as an inducement to practice any patented invention without permission of the patent owner.
©2024 The Lubrizol Corporation. All rights reserved. All marks are the property of The Lubrizol Corporation. 24-623



contact us at
go.lubrizol.com/EP